TBS DISCOVERY Quadrotor

Durable and crash resistant multirotor optimized for dynamic FPV flight

Revision 2014-03-04

The TBS DISCOVERY quadcopter is a durable and crash resistant multirotor optimized for dynamic FPV flight. By implementing the wiring into the frame, the copter is easy to build and outperforms similar quads in terms of FPV range and video link quality. It is perfect for all looking at a durable and highly integrated FPV solution. The DJI Flame Wheel arms as predetermined breaking point protect your electronics and are easily replaceable in the field.



The TBS DISCOVERY comes as two main boards (top and bottom) and optional Flame Wheel arms with accessories. It transforms the popular F450 (Flame Wheel) into a spider quadrotor. The GoPro and FPV camera mount is placed ideally for "no-prop-in-view" pictures. The optional TBS CORE can be placed directly onto the frame or we can install it for you.

Features

- TBS CORE pre-wired incl. sockets for Plug&Play VTx and FPV camera installation
- 50A Current Sensor installed on the board, built for the TBS CORE or similar OSDs
- GoPro and FPV camera mounts
- Power Distribution Board (PDB)
- Traces and pads for clean R/C receiver to Flight Controller wiring
- RSSI trace to the TBS CORE



Before we begin

Thank you for buying a TBS product! The TBS DISCOVERY is a new multirotor aircraft from Team BlackSheep (TBS) and features the best design practices available on the market to date, providing great flying stability and incredible FPV characteristics.

Please read this manual carefully before assembling and flying your new TBS DISCOVERY quadrotor. Keep this manual for future reference regarding tuning and maintenance.

Disclaimer

Our request to you; the aircraft may not be used to infringe on people's right to privacy. We have designed a toy with mind blowing capabilities. It is your responsibility to use it reasonably and according to your experience level. Use common sense. Fly safe. You are on your own. TBS has no liability for use of this aircraft.

- Locate an appropriate flying location
- Obtain the assistance of an experienced pilot
- Practice safe and responsible operation
- Always be aware of the rotating blades
- Prevent moisture
- Keep away from heat or excessive amounts of sunlight



Specifications

Type:	Asymmetric spider quadrotor
Airframe:	Reinforced black fiberglass (top RF transparent, bottom PDB)
Battery:	3S (11.1V) 5000 to 6000mAh or 4S (14.8V) 2500 to 4500mAh LiPo pack
Propellers:	9x5-inch or 10x5-inch (2xCW, 2xCCW)
Motor:	2212 or 2216 class, 700-900kV, 150-220W, 16x19 mm mount pattern
Speed controllers:	18 to 30A 400Hz Multirotor ESCs
Receiver:	5 channels or more
Flight controller:	Standard quadcopter controller with optional GPS module
Current sensor:	v1.1 100A, v1.2 and later 50A on-board
Center of Gravity:	15mm in front of Center of Thrust mark
Duration:	8 to 15min (dependent on drive train and battery system)
Distance:	up to 5km range (and return)
Altitude:	up to 2km / 6000ft
All-up-weight:	1400 to 2000g









Required tools

- Hex screwdrivers (2.0mm and 2.5mm)
- Soldering iron (50 to 100W recommended)
- Solder ($\text{Sn}_{60}\text{Pb}_{40}$ or $\text{Sn}_{62}\text{Pb}_{36}\text{Ag}_2$, multicore flux)
- Propeller balancer (recommended)



Parts list

Before building your TBS DISCOVERY, make sure the following items are included in your kit.

 <p>1x Top frame plate</p>	 <p>1x Bottom frame plate</p>	 <p>1x Pilot camera mount plate</p>
 <p>8x Red aluminum spacers</p>	 <p>36x M3x6.5mm hex fitting screws for spacers and motors</p>	 <p>30x M2.5x5mm hex frame arm screws</p>
 <p>2x Pin headers for R/C (3x8 rows, 2.54mm pitch)</p>	 <p>2x Pin header rows for TBS CORE (2mm pitch)</p>	 <p>2x VTx and camera Molex 1.00 to 1.25mm PicoBlade cables</p>

Required parts

To get in the air the following equipment and parts are needed for assembly.

 <p>4x DJI Flame Wheel arms</p>	 <p>4x 400Hz Multirotor Speed Controller 18-30A</p>	 <p>4x 750 to 900kV brushless motors (incl. prop adaptor and mounting screws)</p>
--	--	--



 <p>4x 9x5 or 10x5-inch propellers (2xCW, 2xCCW)</p>	 <p>1x 3S 5000 to 6000mAh or 4S 2800 to 4500mAh LiPo battery</p>	 <p>1x Multicopter flight controller</p>
 <p>1x R/C receiver (5-channels or more)</p>	 <p>1x R/C transmitter (5-channels or more)</p>	 <p>1x LiPo battery charger</p>
 <p>1x Pilot camera (32x32mm)</p>	 <p>1x HD recording camera</p>	 <p>1x Video transmitter</p>
 <p>1x Equipped ground station</p>	 <p>2x Velcro battery straps</p>	 <p>1x Rubber band</p>
 <p>15x Zip-ties</p>	 <p>2x Self-adhesive foam pads</p>	 <p>1x Threadlock low strength</p>

We offer most of these items on our website individually or as part of an *Almost-Ready-to-Fly* (ARF) and STARTER kit. The equipment and parts we offer has been truly tried-and-tested to meet our standards for an excellent flight experience. But you can of course replace these with equal or similar type. See the parts list at the end of this manual for recommendations.



Frequency choice

Frequency choice depends on the ranges you want to fly. Using 5.8GHz video is an ideal frequency if you do not plan on flying far away from yourself or behind objects. It is compatible with 2.4GHz remote controls.

Using 2.4GHz video (TBS video frequency of choice) will give you nearly unlimited range and far superior link quality, but you can not use your 2.4GHz remote control on the same quad because of limited separation (it is no problem for our R/C buddies to fly with 2.4GHz remote controls next to you though!). You will need an EzUHF or any other UHF control system available on the market.

1.2GHz works very well in urban environments where the 2.4GHz band is completely polluted.

By using the same connector type across all transmission frequencies, the TBS eco-system allows quick and effortless switching between the frequencies.

Typical ranges (based on customer feedback) with omnidirectional antennas:

- Lawmate 2.4GHz 500mW - 4km
- TBS 5.8GHz 25mW - 400m
- TBS 5.8GHz 200mW - 1.4km
- Boscama/Foxtech/HobbyKing 5.8GHz 500mW - do NOT buy, bad design!
- Boscama/Foxtech/HobbyKing 5.8GHz 400mW - 2.5km
- ImmersionRC 5.8GHz 600mW - 1.5km

More range can be achieved by using higher gain (directional) antennas. With the 11dBi TBS Yagi on 500mW Lawmate 2.4GHz gear, 10km of range is no problem at all. The battery normally only lasts for 8km of flight (4km and return.)

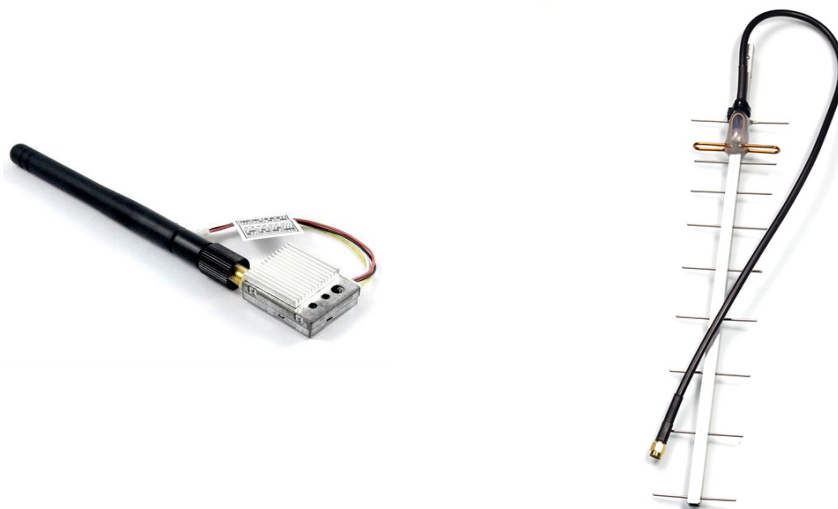

Choosing the right setup

If you are just getting into the hobby and you have absolutely nothing, consider the following components to buy. Use these suggested setups as a “shopping list” if you are just getting started. Any existing gear you already own (e.g. remote controls, chargers, batteries) can be used with the TBS DISCOVERY.

These setups, with the exception of the Camera Tripod and the Remote Control, are available from Team BlackSheep. Remote controls can be purchased at your local hobby shop, camera tripods are available from big electronics wholesalers or Ebay.

TBS DISCOVERY setup for short range flights

- Expected flight time: 8-12 min
- Approximate cost: US\$ 1'600 - US\$ 2'000
- Experience level: Beginner to Expert
- Ideal for: Parks, R/C clubs, front lawns

R/C transmitter/receiver:	Graupner MX-12 2.4GHz radio with bundled receiver (GR-6) or Futaba 8FG / 7C 2.4GHz radio with included receiver (R6208SB / R617FS)
Quadrotor equipment:	4x DJI Flame Wheel F450 arms 4x TBS BULLETPROOF 30A 5V SBEC speed controllers 4x TBS 750kV brushless motors 4x Graupner E-Prop 10x5-inch propellers 1x DJI NAZA-M flight controller (optional GPS add-on)
Battery:	TBS 4S (14.8V) 3300mAh - 4500mAh 35C Lipo pack
Battery charger:	Graupner Ultramat 14S (premium) or TBS B6AC 80W (budget)
FPV transmitter:	TBS ROOKIE BOSCAM 5.8GHz 200mW video transmitter
FPV receiver:	TBS RC508 5.8GHz video receiver or Dominator 5.8GHz module
FPV pilot camera:	TBS 59 or TBS 69 FPV camera
FPV goggles:	FatShark Dominator video glasses
HD camera:	GoPro HD Hero 3 Black edition
Ground station accessories:	TBS 3S 5000mAh Ground Station Lipo Camera Tripod to mount your gear (e.g. Cullmann Primax 150)



TBS DISCOVERY setup for long range flights

- Expected flight time: 8-12 min
- Cost range: US\$ 2'000 - US\$ 2'800
- Experience level: Expert
- Ideal for: Long, wide open fields, plains, coastlines and valleys or urban flying

R/C transmitter/receiver:	Futaba 8FG / 7C or Graupner MX-12 radio + EzUHF 433MHz transmitter module and SRH-771 UHF antenna + EzUHF Lite 8-channel 433MHz receiver
Quadrotor equipment:	4x DJI Flame Wheel F450 arms 4x TBS BULLETPROOF 30A 5V SBEC speed controllers 4x TBS 900kV brushless motors 4x Graupner E-Prop 9x5-inch propellers 1x DJI NAZA-M flight controller (optional GPS add-on)
Battery:	TBS 4S (14.8V) 4500mAh 35C Lipo pack
Battery charger:	Graupner Ultramat 14S (premium) or TBS B6AC 80W (budget)
FPV transmitter:	Lawmate 2.4GHz 500mW Video Tx (stock or tuned)
FPV receiver:	Lawmate 2.4GHz Video Rx (stock or tuned) with 11dBi Yagi
FPV pilot camera:	TBS 59 or TBS 69 FPV camera
FPV goggles:	FatShark Dominator video glasses
HD camera:	GoPro HD Hero 3 Black edition
Ground station accessories:	TBS 3S 5000mAh Ground Station Lipo Camera Tripod to mount your gear (e.g. Cullmann Primax 150)



Frame assembly

Begin by assembling the base of the frame and soldering the speed controller, battery lead and flight controller to the bottom power distribution board (PDB). In addition to the following assembly instructions, we have a professionally produced "[How To](#)"-video on our website showing the assembly and electronics installation.

A more detailed image of the frame assembly is available as an appendix to this document.

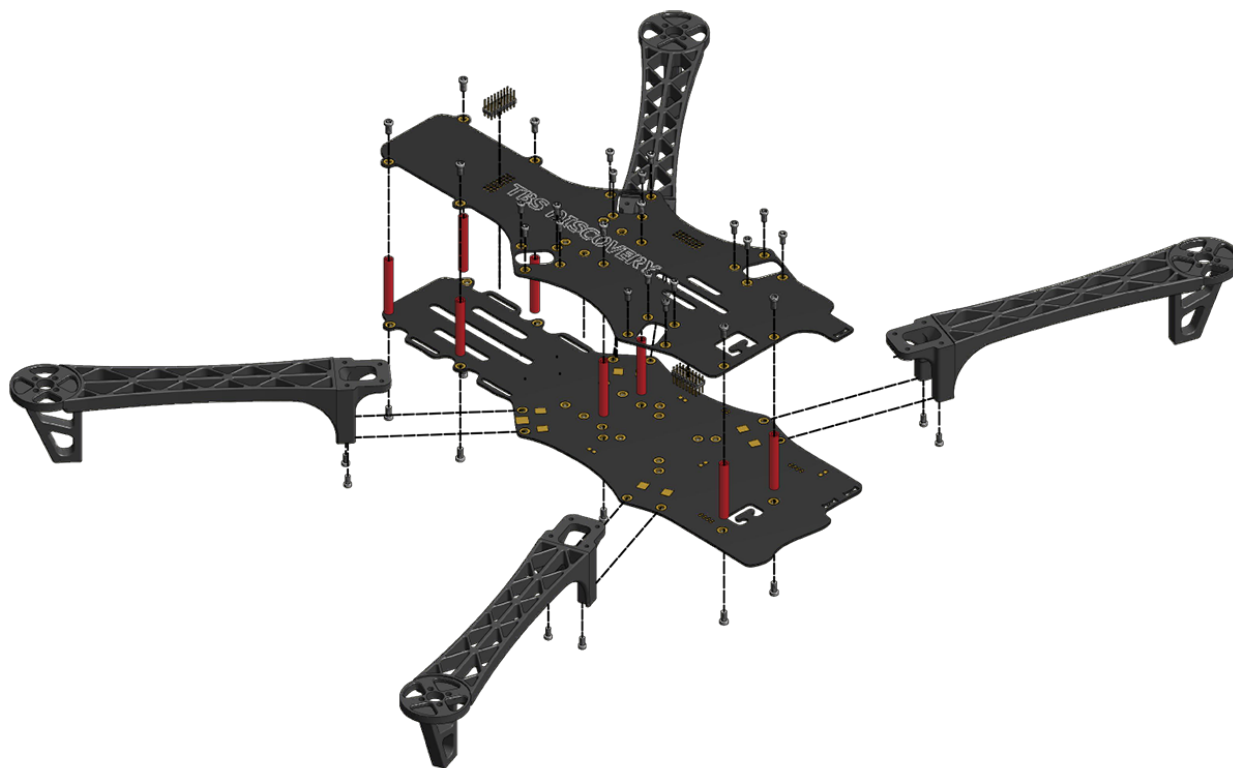

Bottom plate

Power distribution

- Start by cutting the power pigtail to 12cm and pre-tinning (add solder to) the battery pads, speed controller pads, auxiliary power pads (for flight controller power), speed controller power leads and the battery pigtail. If needed, desolder and change the XT60 connector to your preferred connector of choice.
- Solder the battery pigtail to the positive (red) and negative (black) pads located on the back-right side. Do the same for the speed controllers; solder the speed controller power leads to the positive and negative square pads located next to the four frame arm screw holes on both sides. Heat the solder pad, hold the cable in a slight angle (so both cables will form a "V"), remove the solder iron and keep still for the solder to settle nicely.
- Pick one of the available auxiliary power pads (smaller squares) and solder the flight controller power unit and/or voltage regulator(s) to the frame. We recommend the pads on the middle-left side.



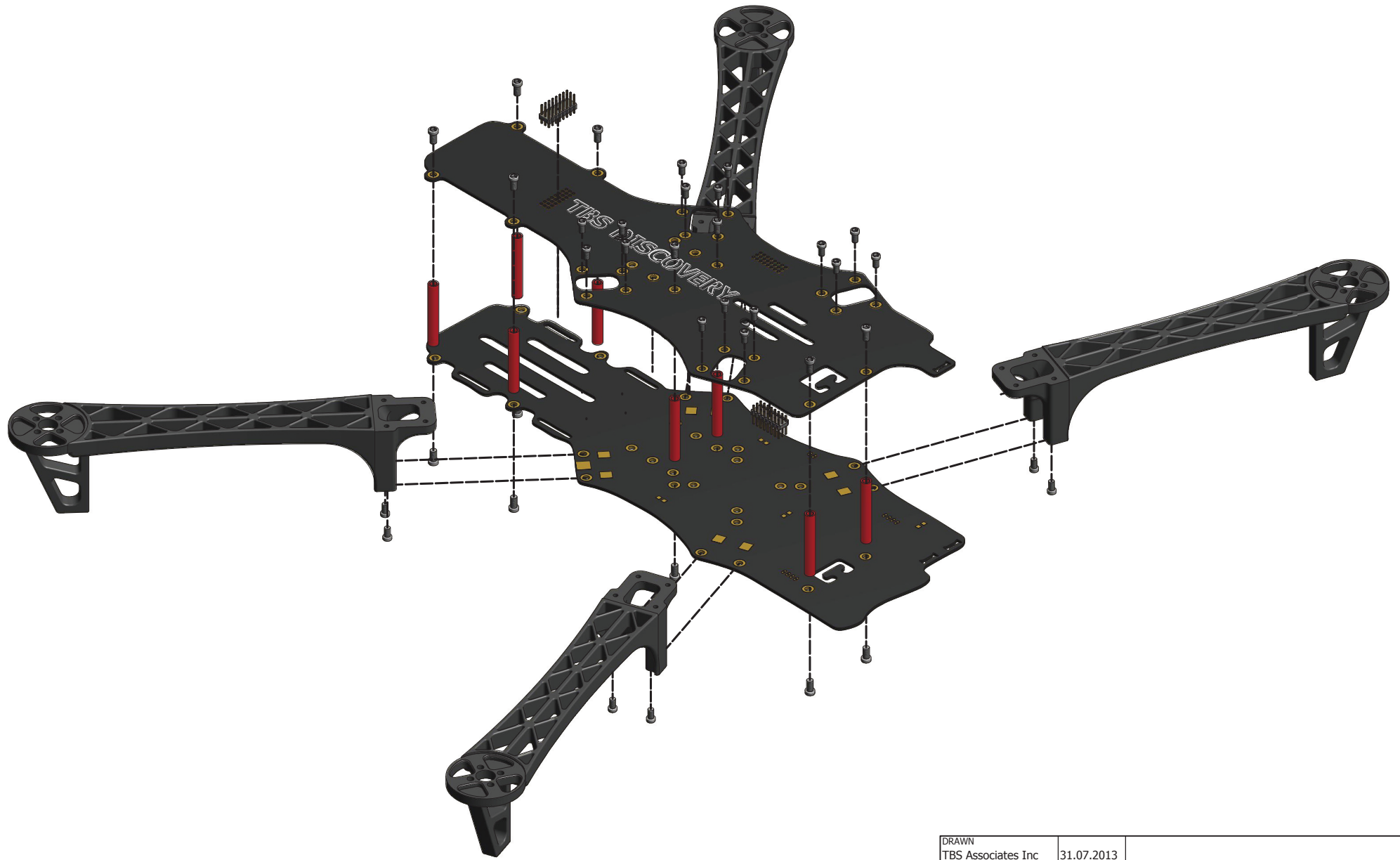

DRAWN		31.07.2013			
TBS Associates Inc				TITLE	
CHECKED					
QA					
MFG					
APPROVED					
		SIZE	DWG NO	REV	
		A2	tbs_discovery_pro_frame		
		SCALE	SHEET 1 OF 1		

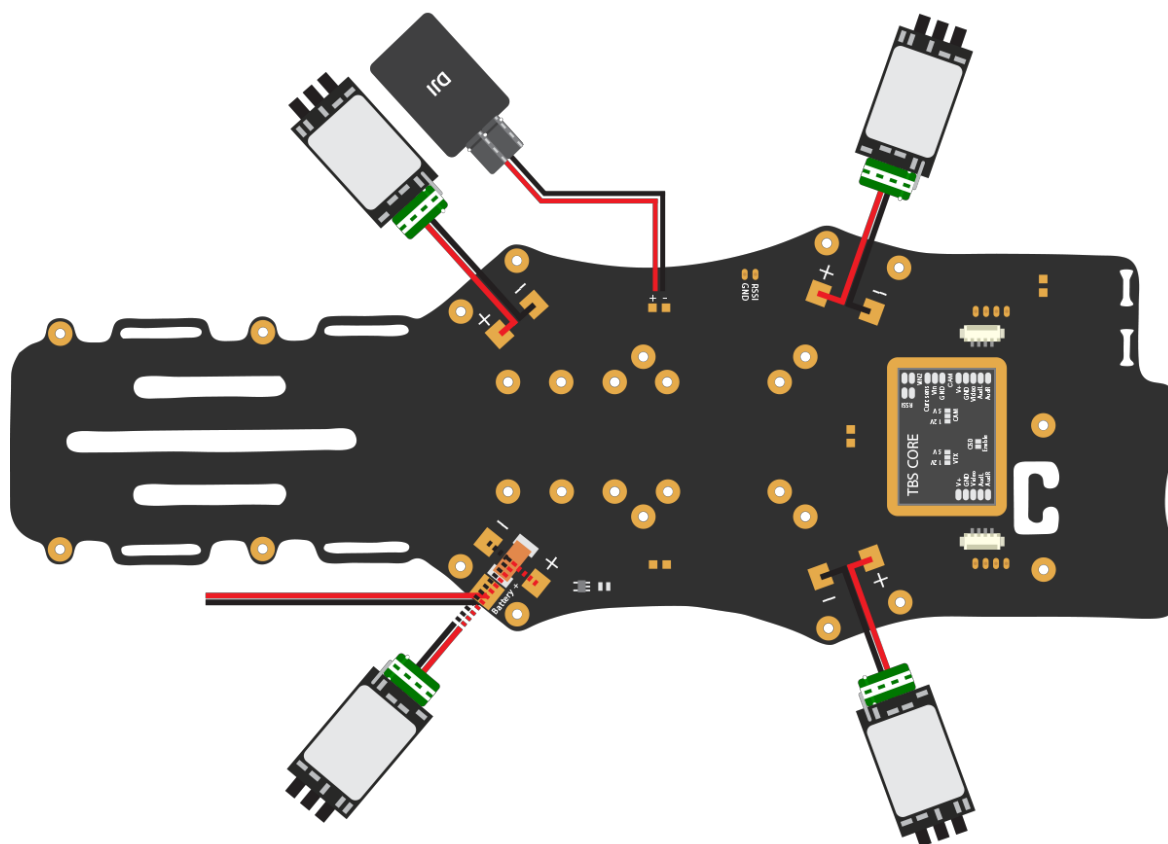

Spacers

- Next, add the red spacers (posts) to the bottom frame plate using the supplied M3x6.5mm hex screws. Add a small drop of threadlock to help secure the frame. It is recommended to only apply on the bottom screws for easy repairs/maintenance.
- There are three spacer positions in the battery compartment to make it easy to balance (CG) the frame. The middle spacer position is great for 4S 3300-3700mAh packs, while the most forward position is great for 4S 4000-4500mAh packs.

Frame arms

- Install the frame arms on the four designated locations using the long-neck M2.5x5mm screws. Feed the speed controller wires through the gap between the frame arm and bottom plate.
- Secure the ESCs below the frame arms with 3 zip-ties. One to secure the cables before the ESC, one to secure the cables after the ESC, and one around the whole ESC unit.
- Feed the battery strap through the two slots in the battery compartment. Only one strap is really necessary to provide adequate friction.

Optional: Use different colored frame arms for the front and back pair to make it easier to identify the orientation of the quadcopter in the air.



Top plate

R/C control signal headers

- To get a clean R/C receiver-to-flight controller wiring, it is recommended to use the traces routed on the top plate. There are 8 traces to support up to equally many PWM (Pulse Width Modulation) channels. When using a PPM (Pulse Position Modulation) compatible receiver and flight controller, only one trace (Channel 1) is used.
- Solder the supplied pin headers to the 8x3-pads. Install the first header on the R/C receiver side (back) with the pins pointing up and the second header with the pins pointing down (towards the bottom plate/flight controller.) Use tape to keep the header in place while applying a reasonable amount of solder to all of the pins while applying heat. The flux in the solder will make the solder flow around the pins.
- When using the RSSI (Received Signal Strength Indication) signal from a compatible R/C receiver, use one of the eight channels pins to supply the signal (via a cable) to the designated RSSI header on the bottom plate (which is connected directly to the TBS CORE). Or connect the output directly to your OSD system of choice.

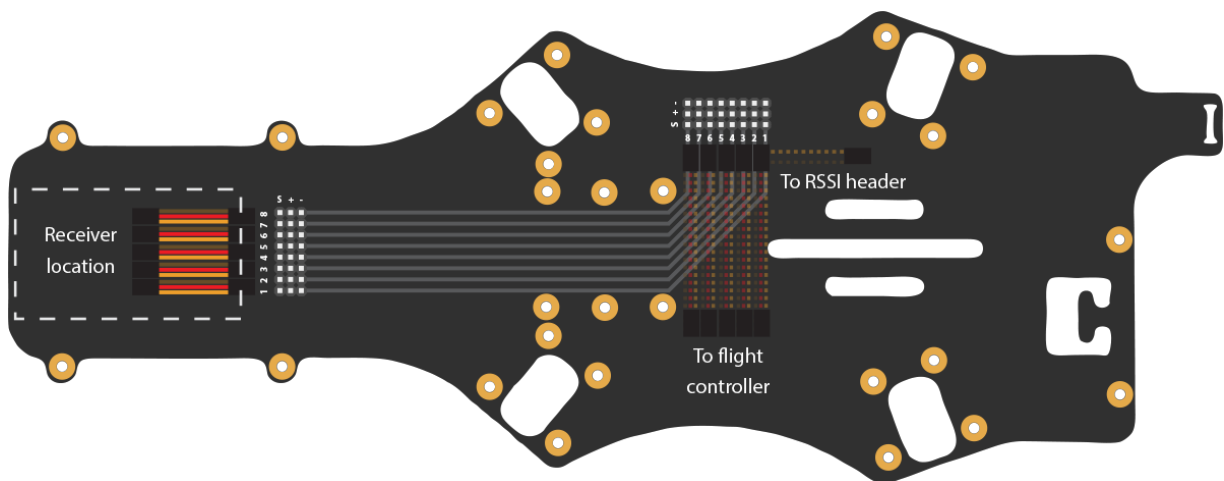

Electronics installation

The electronics installation is split into two sections; one for the R/C equipment and the second for the FPV gear. We recommend finishing and dry-testing the R/C system before moving on to the FPV section to simplify troubleshooting. A detailed overview diagram of the electronics installation is available as an appendix to this manual.

Before adding the equipment to the frame it is a good idea to become familiar with the recommended positioning of the equipment, as shown in the image below.

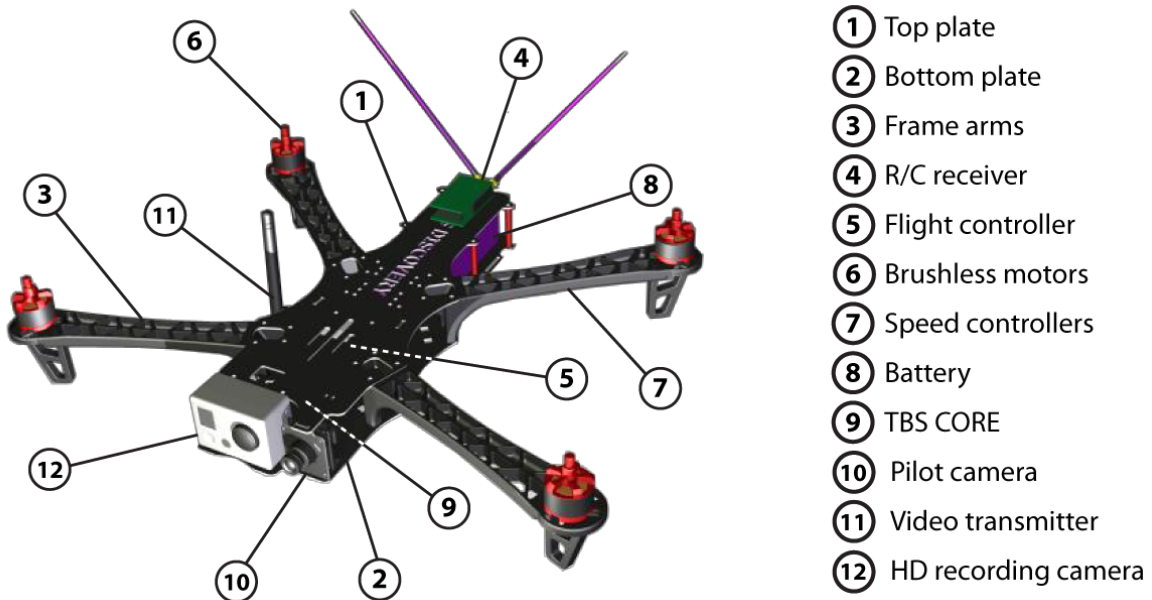

R/C equipment

R/C receiver

- Plug in the short servo extensions on the header on the top plate and connect them to the R/C receiver. Use a self-adhesive foam pad to mount the unit to the back-end of the top plate. Mount the antenna(s) in a vertical and/or "V"-formation using nylon antenna tube(s).
- The table below shows the normal channel alignment for Futaba/Hitec radios, while JR/Spektrum has throttle on channel 1 and the remaining shifted down.

R/C receiver	Ch. 1	Ch. 2	Ch. 3	Ch. 4	Ch. 5	Ch. 6	Ch. 7	Ch. 8
Flight controller	Aileron/P PM	Elevator	Throttle	Rudder	Unused/ gain	Unused/ gain	Flight mode	RSSI output

- When using the RSSI (Received Signal Strength Indication) signal from a compatible R/C receiver, use the laster header pin to supply the signal to the CORE. Make sure to enable the proper RSSI type in the CORE menu (either analog or digital) and calibrate the max./min.





TBS DISCOVERY

fpv quadcopter

Electronics installation

by ivc.no/tbsdiscovery - 08.2013

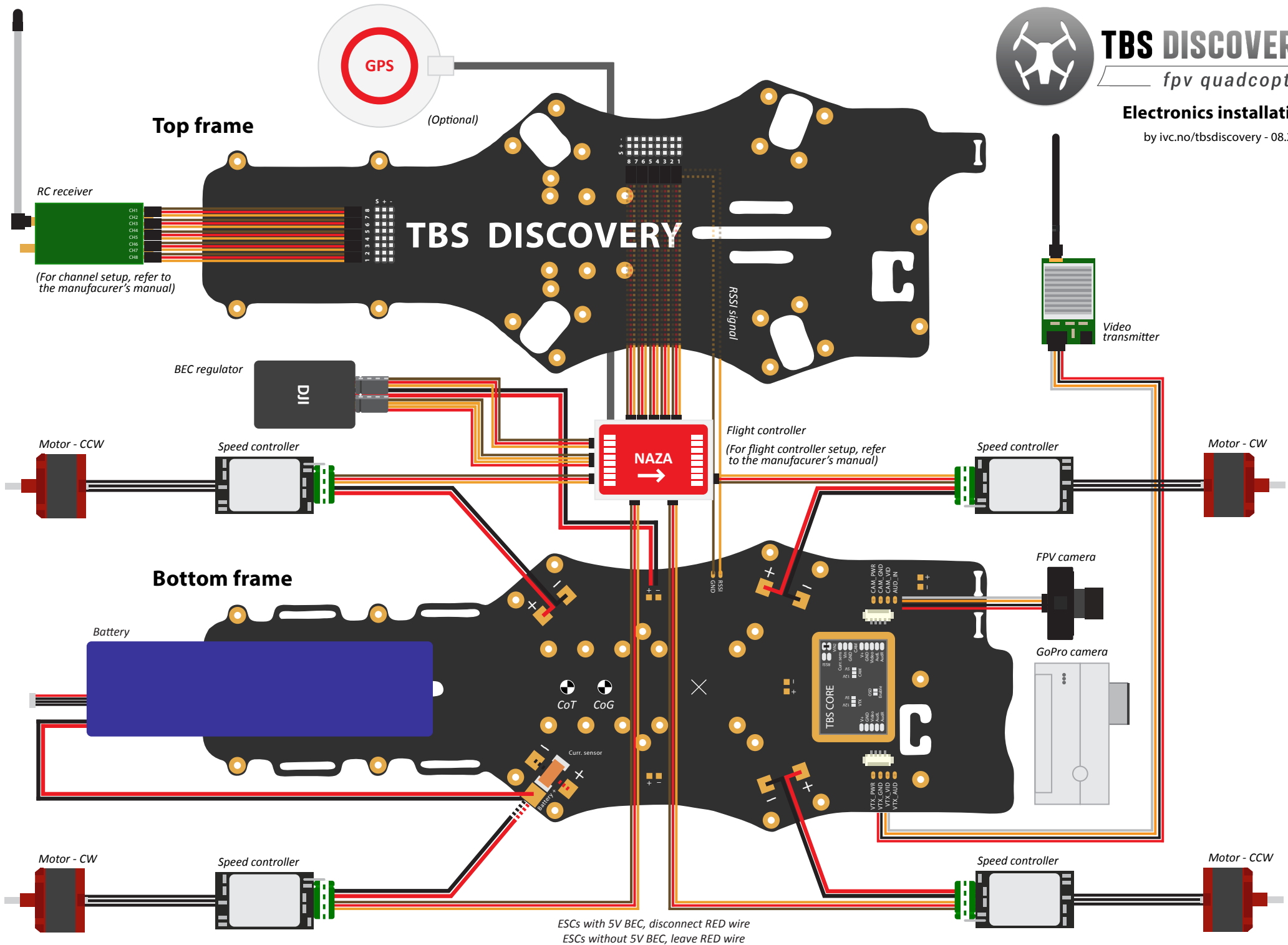

ESCs with 5V BEC, disconnect RED wire
ESCs without 5V BEC, leave RED wire

Flight controller

- Decide whether you want to use traditional PWM or PPM mode. As of writing, TBS suggests the DJI NAZA-M flight controller in PPM mode (together with a compatible receiver) and an optional GPS add-on (for return-to-home capability) for a clean wiring layout and great out-of-the-box experience.
- Plug in all the R/C and ESC cables to the flight controller according to the flight controller instructions, and mount the unit on the bottom plate in the centre of the four holes and two parallel lines. Use a self-adhesive foam pads to dampen the controller slightly. Be sure to double check the orientation of the flight controller for proper operation.
- For setup and tuning parameters of the flight controller, refer to the manufacturer manual or guides on fpvlab.com.
- (DJI NAZA only) Open NAZA Assistant and disable the Voltage Monitor Protection. This prevents the DISCOVERY PRO from prematurely descending on low battery. Use the CORE OSD to watch the battery condition instead. Never let the voltage go past 3.5V x cell count (3S 10.5V, 4S 14.0V) or current consumption over 80% of a full pack (e.g. max. 3600mA discharged of a 4500mAh battery.)

Start out using the following suggested NAZA-M Autopilot gains and *tune according to your preferences*.

Setup	Gain	Pitch	Roll	Yaw	Vertical
TBS 750KV 10x5 4S3300mAh 30A	Basic/manual	134%	109%	93%	198%
	Attitude	183%	143%		
TBS 900KV 9x5 4S3300mAh 30A	Basic/manual	166%	135%	131%	179%
	Attitude	188%	176%		
Other drivetrain setups (generally)	Basic/manual	150%	140%	120%	110%
	Attitude	140%	140%		

Note: The pitch axis gain will in most cases be greater than the roll axis gain because of the inherent asymmetric design and weight distribution on the frame.

Motors

- Mount the brushless motors to the frame arms using standard M3x6.5mm hex screws supplied with most brushless motors. Apply a small drop of medium threadlock to a secure the motors. Feed the motor wires through the frame arm comb-pattern to minimize clutter.
- Plug in the bullet-connectors to the speed controllers. Swap any two wires to change the direction of rotation if they do not rotate as shown below. See the image below for the most commonly used setup (e.g. NAZA-M, OpenPilot controllers are vertically mirrored).



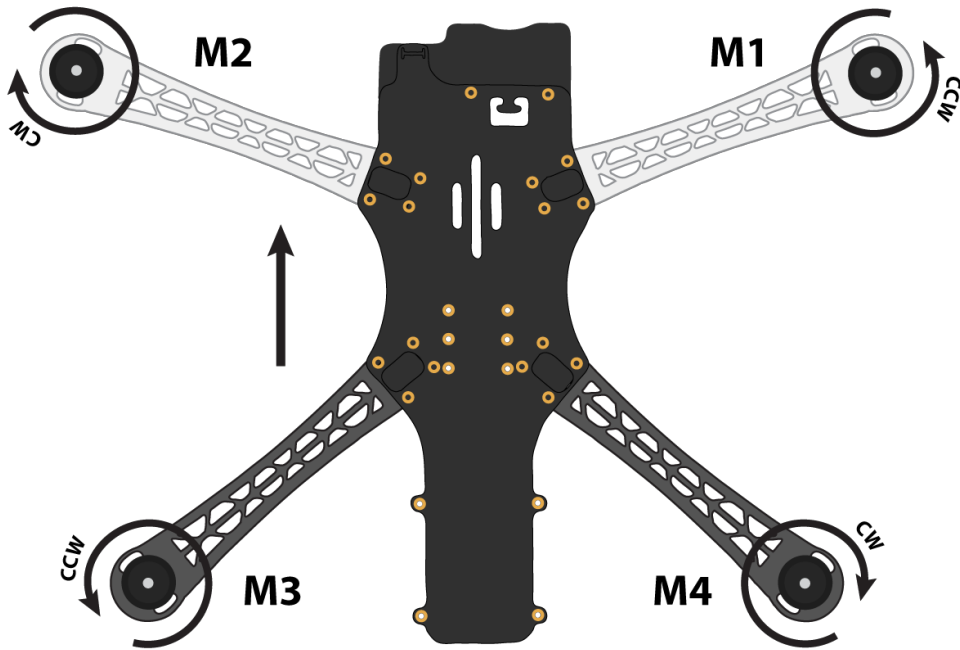

Speed controllers

- With the frame arms mounted, use the zip-ties to mount the speed controllers to the underside of the arms. Avoid putting tension or stress on the motor- or speed controller-cables. Use a self-adhesive pad to mount any BEC or control unit (e.g. NAZA PMU/VU-unit.) to the underside of the back-left speed controller.
- Calibrate the throttle range for each ESC individually (except for DJI and TBS BULLETPROOF ESCs) by connecting the ESC directly to the throttle channel on the receiver and setting the throttle stick high (WOT) on power-on and then low until a confirmation beep is heard (motors attached). The ESC has to be connected directly to the R/C receiver for this procedure to work. TBS is offering a handy calibration cable for this purpose. If you are using EzUHF, set WOT as failsafe to avoid start-up timing issues. The TBS BULLETPROOF ESCs come pre-calibrated and do not need to be re-configured.
- One important note for ESCs that do not carry the "OPTO" label or are not TBS BULLETPROOF designs, is that only one of the four ESCs should provide BEC 5V power to the flight controller. The middle red wire on the end connector should be disconnected on three of the ESCs. If the flight controller is providing power (e.g. NAZA-M VU-unit), all ESC BECs should be disconnected. The reason for this is to avoid voltage oscillations caused by erroneous voltage-regulator feedback.

Propellers

- Before adding the propellers it is a good idea to be sure they are balanced, as mentioned later on. To avert any chance of injury, **leave the propellers off** until the flight controller configuration has been completed.



- The only recommended propeller installation method is to use a precisely manufacturer prop adaptors (never prop-saver with o-ring). The layering should be as follows; *prop adaptor, propeller, washer* and *(lock) nut*. You can skip any bell screw as it may add unnecessary vibrations.
- The TBS 750kV and 900kV motors have a 5mm prop shaft. This is compatible with Graupner 9x5-inch propellers. For Graupner 10x5-inch propellers you will need aluminium 8mm-to-5mm reduction spacers available separately.
- Try to match the motor and propeller to suit your particular need. For extended flight time try to achieve optimal efficiency. For agile-flight get a responsive combination. Our general recommendations are listed in the table below.
- A thumb of rule would be that smaller props equals less flight time and higher kV motors equals smaller props or lower battery cells count (than the reference below.) Note that 10-inch is the maximum propeller size that can fit on the DISCOVERY.

Motor type	Propeller	Flight characteristic
TBS 750kV brushless motor	9x5-inch Graupner type	locked in
	10x5-inch Graupner type	long flight time
TBS 900kV brushless motor	9x5-inch Graupner type	super responsive, locked in
	10x5-inch Graupner type	long flight time
DJI 920kV brushless motor	10x5-inch Graupner type	long flight time



FPV gear

The FPV gear is designed to be installed on the front section of the frame to achieve as much separation between the R/C- and FPV-radio environment as possible. Keep in mind that the former is listening while the latter is broadcasting. The quieter the receiving conditions are, the better range and reliability will be.

At the heart of this system sits the (optional) TBS CORE which provides a rudimentary OSD and clean power distribution to the camera and video transmitter, regardless of input voltage. The frame already includes a current sensor (50A) that works together with the TBS CORE to show current consumption during flight.

Power supply

- To eliminate noise from causing problems on the FPV-side of the system, use a properly filtered power supply. Any type will work but the TBS CORE is made to provide selectable 5V and/or 12V to the video transmitter and camera regardless of input voltage (2S to 10S). It can supply video transmitters with up to 1W (with minor airflow at 1W) of emitted power (EIRP) and a standard FPV camera.
- If you are planning to fly with UHF, we highly recommend the Tin Shield to isolate the CORE nicely from the rest of the electronics on board.
- Configure the CORE according to the required voltage for the FPV gear; pads marked VTX and CAM can be configured to either 12V (0.65A max.) or 5V (2A max.). Solder a bridge between the middle pad to either side for 12V or 5V. Do not solder all three pads.

Pilot camera

- Use the supplied camera plate to mount the pilot camera. The mounting pattern is designed to be compatible with most standard 32x32 mm board cameras. You might need to break-away excessive board support. Either use two small zip-ties, rubber bands or four M2x15mm screws and nuts (not supplied) to mount the camera (use threadlock.)
- Plug in the cable connector for the camera and insert the tabs on the top and bottom of the camera frame in the corresponding routed gaps on the frame. For a secure mount, you can add solder to the three exposed solder spots (v1.3 boards or later), or leave it for easy hot swapping in the field.
- Decide whether you can use the supplied wires and connector socket on the top frame or connect the camera and video transmitter via the round solder pads. The supplied picoblade Molex cable "5V VTX" are designed to work with the TBS GREENHORN, TBS ROOKIE, Lawmate video transmitters, and the supplied "12V CAM" cable with the TBS59/TBS69 cameras respectively. You can of course modify and solder the wires to suit your specific need.



Video transmitter

- Put the video transmitter close to the front on the top plate. Use zip-ties and/or self-adhesive foam pads to fit the transmitter. TBS offers a custom made mounting bracket for easy vertical install over the front-right frame arm.

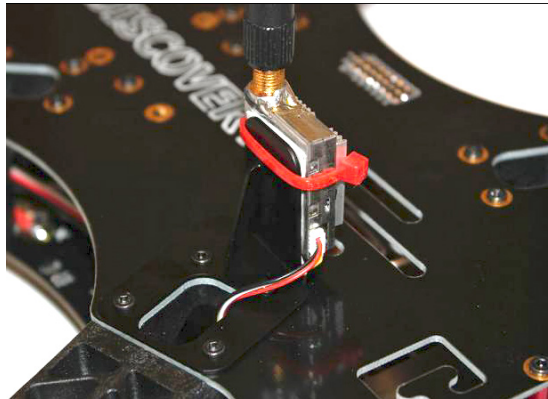

- To avoid possible video interference, be sure to use a foam or gel pad between the frame and VTx unit to reduce vibrations.
- The kit includes a small JST cable which is compatible with Lawmate 500mW VTx as well as our TBS GREENHORN and TBS ROOKIE. For FatShark VTx you need to cut the cable and solder your FatShark cable onto it.

OSD (On Screen Display)



- You can use an optional (but recommended) OSD add-on to get live readout on screen about the battery voltage (V), current draw (A), total current consumption (mAh), receiver signal strength (%) and flight time (minutes:seconds), position (coordinates) and home location, to name a few. For a basic feature set we recommend the TBS CORE which provide all but the latter two data points. A full feature set will require an OSD with a GPS module (e.g. TBS EzOSD).



TBS DISCOVERY / DISCOVERY PRO - Video transmitter (VTx) setups

TBS/Lawmate VTx

- 1.2G 500mW
- 2.4G 100mW, 200mW, 500mW
- 5.8G 25mW (TBS Greenhorn), 200mW (TBS Rookie), 500mW (TBS Boss)

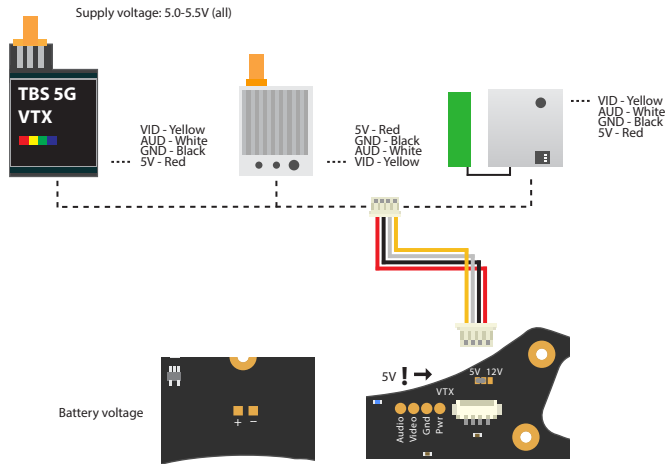

- 1.2G 1000mW
- 2.4G 1000mW

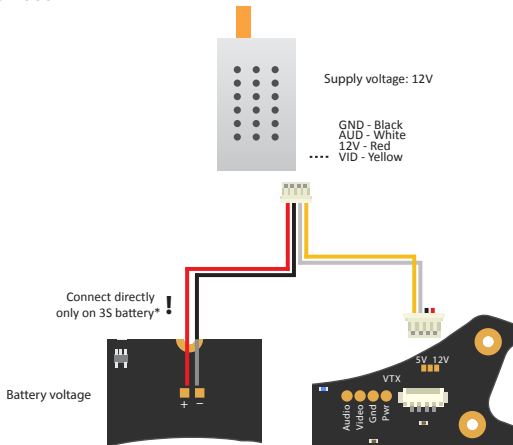

Boscam VTx

- 2.4G 500mW
- 5.8G 200mW, 400mW, 500mW

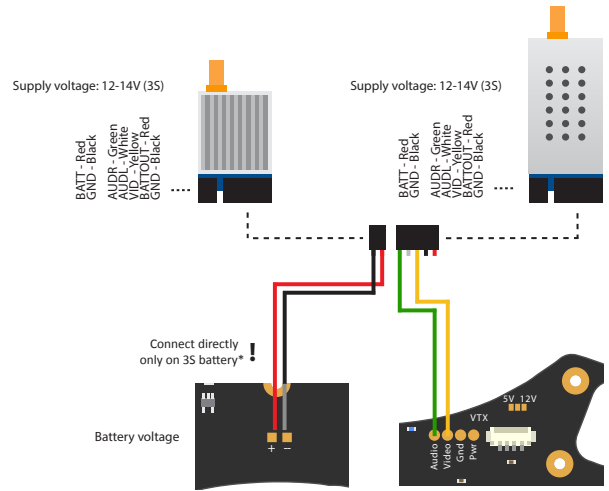

Racewood VTx

- 1.3G 500mW

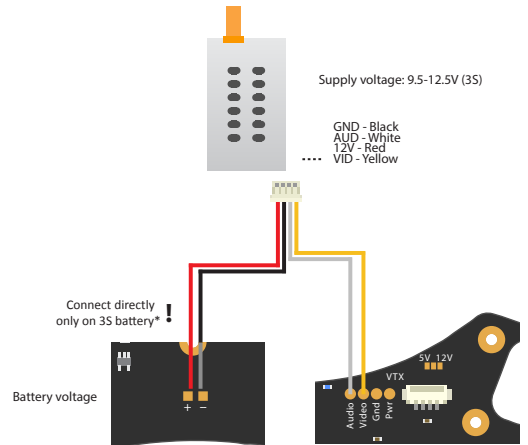

FatShark/ImmersionRC VTx

- 5.8G 25mW, 250mW

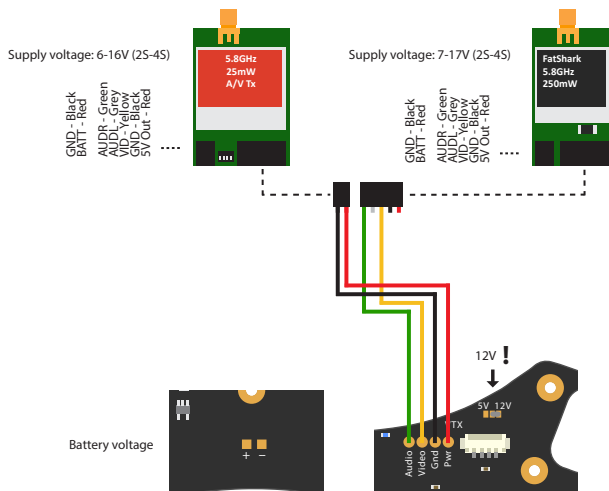

- 5.8G 600mW

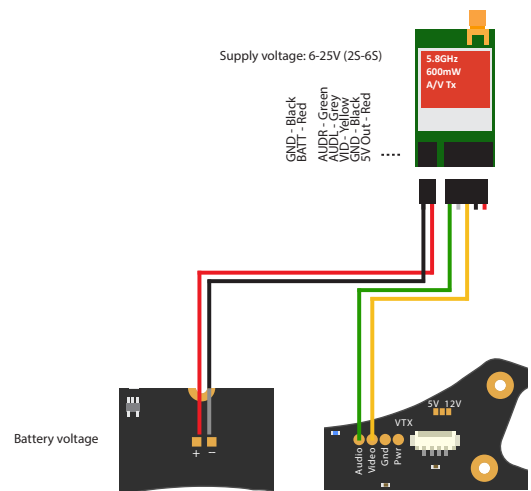

Note: Connecting a video transmitter directly to a shared battery source may induce interference on the video image. Consider adding a filter between the solder pad and video transmitter.

* On 4S+ setups where 12V is not available, consider using a dedicated TBS CORE PNP to supply power to the video transmitter.

- To enable the CORE OSD, solder a dab between the two pads labeled “OSD Enable” on the TBS CORE board.
- The bottom plate has a RSSI trace leading directly to TBS CORE. The RSSI input header is located on the middle-left side, right beneath the top pin header for easy connection directly from a supported R/C receiver. All major FPV R/C system vendors support either analog or digital (PWM) RSSI output. The TBS CORE documentation shows how to configure and calibrate the RSSI.
- The next feature is a market first and it is a on-board current sensor on the back-right side, next to the battery connection. Coupling this with the RSSI input makes a clutter-free and clean build.
- To take advantage of the current sensor you only need to have a TBS CORE installed at the designated area. The TBS CORE has to be configured to 100A for v1.1 frames and 50A for v1.2 and later frames. Instructions on how to install the TBS EzOSD can be found here: bit.ly/13oXPbj.

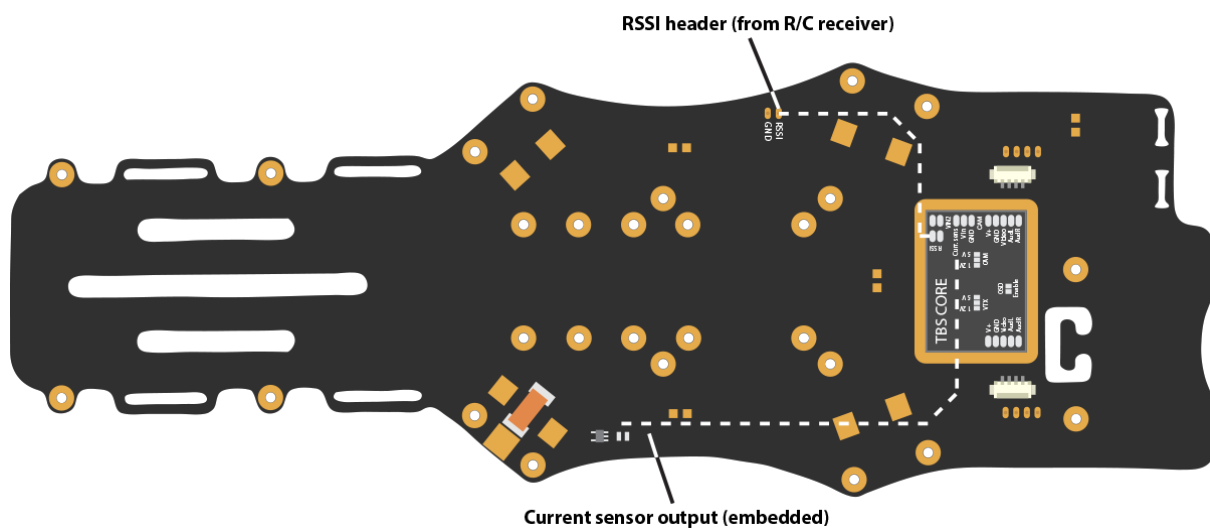

- Lastly, when all the R/C and FPV gear is installed, connect any the remaining R/C or RSSI cables to the top plate and close the frame. Use the remaining spacer and frame arm screws to secure the frame.

Caution: When testing for shorts on the TBS CORE, you may notice that VIN2 pins are shorted. This is completely normal and per design. Other neighboring pins should not be shorted!



Mounting HD camera

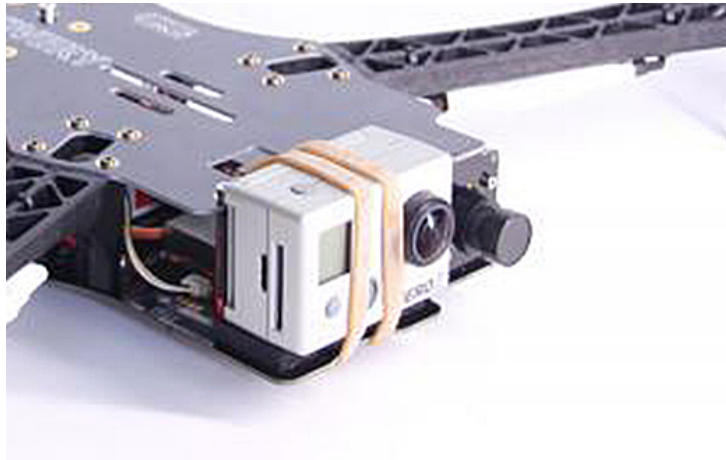

GoPro HD Hero

- The GoPro HD Hero camera is the most commonly used HD recording camera (as of writing) and was the camera of choice during the design process of the TBS DISCOVERY.
- A little background on how modern HD video cameras function; the GoPro uses a method called *rolling shutter* to capture video frames, as the name suggests, it is scanning across the image sensor horizontally to record a single image (opposite to a single snapshot of a point in time of the entire image sensor). This can cause issues when coupled with high frequency vibrations produced by the drivetrain on a multirotor. If the frequency is close or matches the scanning frequency, the image sensor will capture the minute movement (resonate with the vibrations). This will cause the video to have clearly visible wavy wobbly lines, or more commonly known as “jello”-effect.

Vibration free footage

- To get rid of most of the “jello”-effect, it is (always) good practice to begin with eliminating the root cause of the vibrations rather than trying to apply various dampening methods.
- The primary culprit is unbalanced propellers, followed closely by unbalanced motors. Fortunately, balancing them is a relatively easy task. TBS is offering a Prop Balancer for this purpose. More details on how to perform the balancing, see our support forum at fpvlab.com.
- To reduce vibrations from propagating to the GoPro, use memory foam to add a separation layer which absorbs the energy. Use the specially designed TBS Loveseat or cut two large pieces which will cover the bottom and back of the GoPro. Secure the camera to the frame using two thin rubber bands.

Consider using the GoPro settings in the tables below for “no-prop-in-view” and stable footage.



GoPro HD Hero1:

Video format:	NTSC	to get 30fps
Video resolution:	1080p 30fps (medium angle)	for 10x5-inch props
	720p 30fps (wide angle)	for 9x5-inch props

GoPro HD Hero2:

Video format:	NTSC	to get 30fps
Video resolution:	1080p 30fps	high quality video
Video angle:	Medium (127 degrees)	for 10x5-inch props
	Wide (170 degrees)	for 9x5-inch props

GoPro HD Hero3:

Video format:	NTSC	to get 30/60fps
Video resolution:	1080p 60fps	less chance of "jello"
Video angle:	Medium (127 degrees)	for 10x5-inch props
	Wide (170 degrees, padding needed behind camera)	for 9x5-inch props



Center of Gravity optimization

- A properly balanced multirotor will distribute the weight (mass) equally over the four motors. The mark on the bottom plate is the Center of Thrust (CT, CoT) mark and the Center of Gravity (CG, CoG) spot is 15mm forward of this mark. When holding the frame in the air at the CG spot it should ideally be level and not dip to either side.
- After completing the build and loading up the frame, adjust the CG over the lateral (pitch) axis by primarily moving the battery pack forward or backward. You might need to move the middle two frame spacers to accommodate the battery. The CG over the longitudinal (roll) axis should be in the center of the frame front-to-back and should only need slight adjustments.
- When the frame is out of balance some motors are going to have to work harder than others and you will have less authority in a given axis due to the fact that one or more motors are already working more than normally required. Small balance variations are countered very well by the flight controller and should not cause any problems.
- If the quadcopter is too nose heavy it will bob up and down in forward flight and if it is too tail heavy it will get very twitchy and hard to fly.
- As a side note, the flight controller does not need to be over the CG spot. It should be mounted in the center of the white rectangular lines on bottom plate.

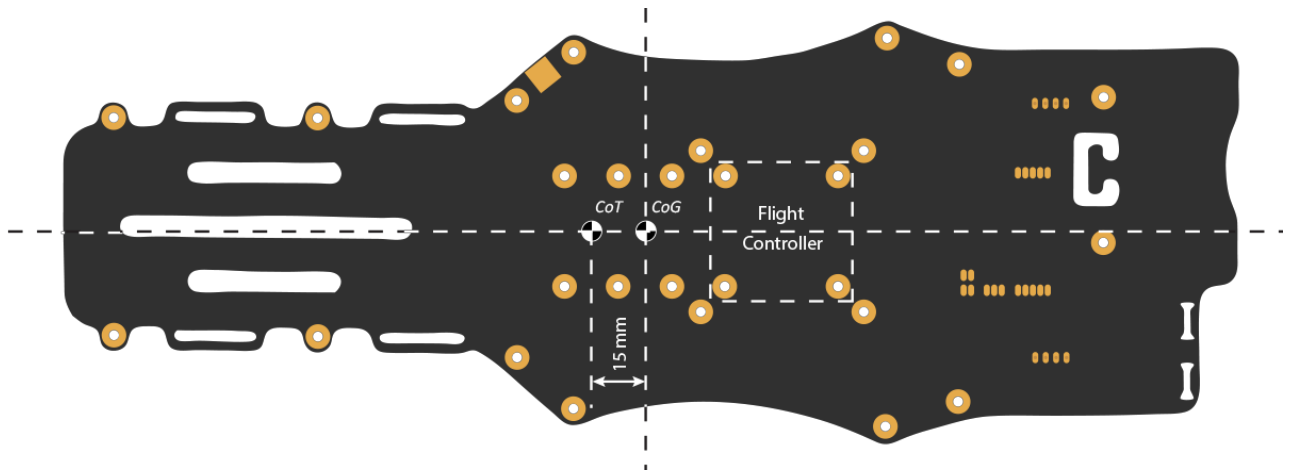



Center of Gravity diagram

by ivc.no/tbsdiscovery - 02. 2013

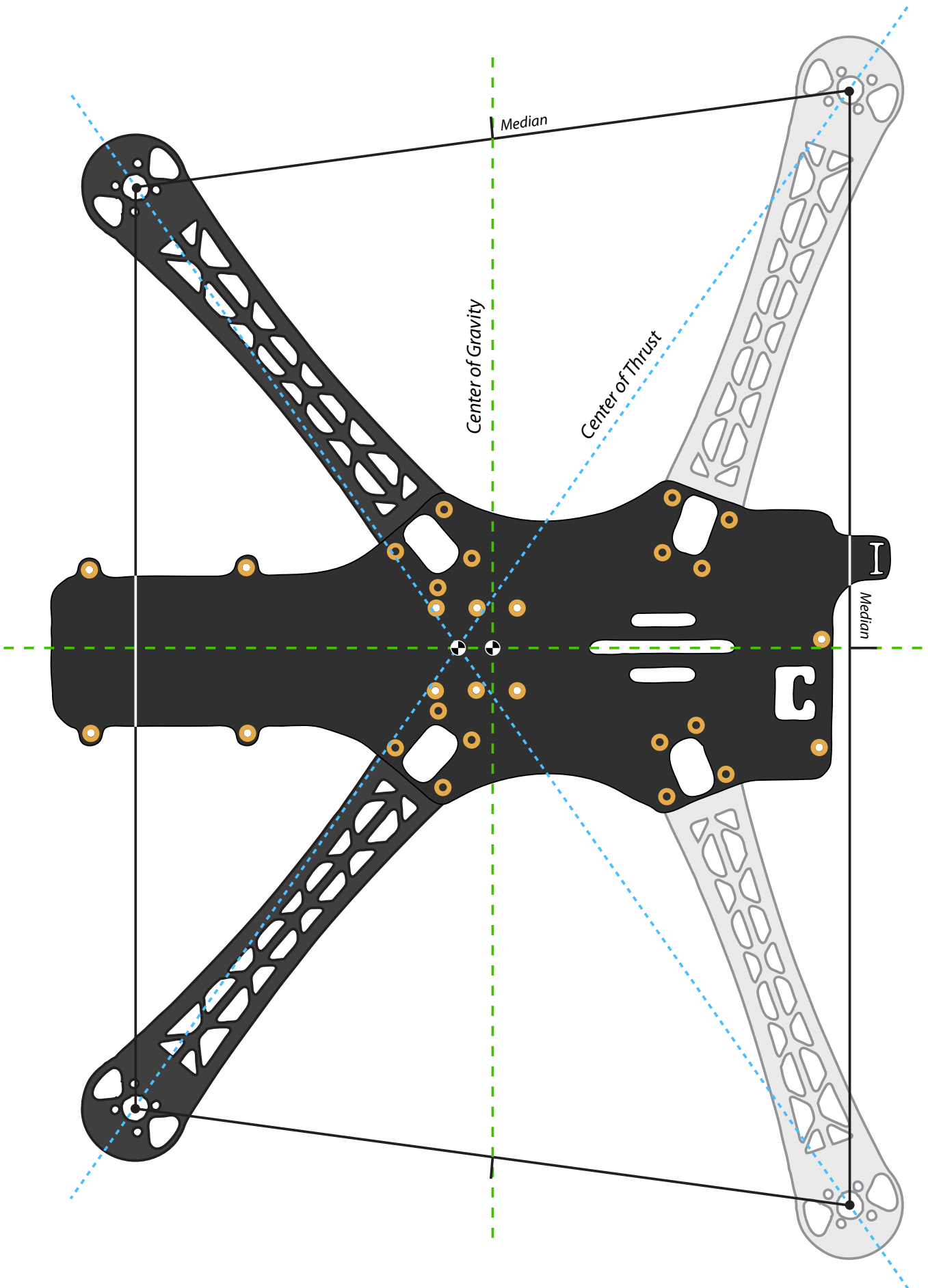

Flight

First flight

Check that the flight battery and transmitter battery is fully charged. Make sure all the screws on the frame and the propellers are secured, and that the battery strapped down. Balance the quadcopter around the Center of Gravity (CG) spot by repositioning the battery.

Find an wide open location free from obstacles, dust and distractions (e.g., garden or park.) The flight conditions should be calm with only a light breeze. Flip the flight mode switch to "Attitude" mode and execute the stick combination to arm the flight controller (e.g., for NAZA left stick to bottom-left and right stick to bottom-right.) Slowly raise the throttle stick and when the propellers start to spin, make sure they rotate in the right direction and the propeller type is correct (right-hand or left-hand turn.)

Takeoff

With all the essentials checked, stand behind the quadcopter with the gimbal facing away from you. Raise the throttle to about 50% where the quadcopter should start to lift-off and hover. Control the hover by primarily using the aileron and elevator sticks. Remember, only small stick movements. If the stick works in the opposite direction than expected, invert the channel and watch the flight controller monitor to confirm.

Let go of the sticks and observe if it drifts in either direction. Compensate by adding 2 or 3 clicks of trim on the radio in the opposite direction. If the quadcopter still drifts, land, put the frame on a level surface, balance the frame and cycle the power to the flight controller to re-initialize the gyro calibration.

FPV

After the quadcopter has been tweaked to stay still in a hover and fly true, turn on the FPV equipment and do a range test to verify that the video link is reliable. Visual inspect the area to pick out noteworthy landmarks and use these to orient yourself once your are in the air. Get a friend or assistant to be your spotter during the entire session.

While still flying line of sight (LOS), takeoff and hover the quadcopter as normal, attain reasonable altitude, and with the video goggles ready on your head, put them on (or turn to the display) to engage in FPV flight. If the picture gradually weakens (noise blends in) or video suddenly drops, increase altitude and return to home, as this normally indicates that you fly at the edge of the video range or behind obstacles, respectively.



Good practices

We have compiled a list of all of the things that have been tried and tested in countless environments and situations by TBS crew and other experienced FPV pilots.

Follow these simple rules, even if rumors on the internet suggest otherwise, and you will have success in FPV.

- Start with the bare essentials and add equipment one step at a time, after each new equipment was added to proper range- and stress tests.
- Do not fly with a video system that is capable of outperforming your R/C system in terms of range.
- Do not fly with a R/C frequency higher than the video frequency (e.g. 2.4GHz R/C, 900MHz video).
- Monitor the vitals of your plane (R/C link and battery). Flying with a digital R/C link without RSSI is dangerous.
- Do not use 2.4GHz R/C unless you fly well within its range limits, in noise-free environments and always within LOS. Since this is most likely never the case, it is recommended to not use 2.4GHz R/C systems for longer range FPV.
- Do not fly at the limits of video, if you see noise in your picture, turn around and buy a higher-gain receiver antenna before going out further.
- Shielded wires or twisted cables only, anything else picks up RF noise and can cause problems.
- When using powerful R/C transmitters, make sure your ground station equipment is properly shielded.
- Adding Return-To-Home (RTH) to an unreliable system does not increase the chances of getting your plane back. Work on making your system reliable without RTH first, then add RTH as an additional safety measure if you must.
- Avoid powering the VTx directly from battery, step-up or step-down the voltage and provide a constant level of power to your VTx. Make sure your VTx runs until your battery dies.
- Do not power your camera directly unless it works along the complete voltage range of your battery. Step-up or step-down the voltage and provide a constant level of power to your camera. Make sure your camera runs until your battery dies.
- A single battery system is safer than using two dedicated batteries for R/C and FPV. Two batteries in parallel even further mitigate sources of failure.
- For maximum video range and "law compatibility", use 2.4GHz video with high-gain antennas.
- When flying with R/C buddies that fly on 2.4GHz, or when flying in cities, it is perfectly possible to use 2.4GHz video provided you stick to the channels that do not lie in their band (CH5 to CH8 for Lawmate systems, available from TBS).
- Do not use diversity video receivers as a replacement for pointing your antennas, diversity should be used to mitigate polarization issues.
- Improving the antenna gain on the receiver end is better than increasing the output power (except in RF-noisy areas). More tx power causes more issues with RF on your plane. 500mW is plenty of power!



-
- Try to achieve as much separation of the VTx and R/C receiver as possible to lower the RF noise floor and EMI interference.
 - Do not buy the cheapest equipment unless it is proven to work reliably (e.g. parts falling off, multitudes of bug fix firmware updates, community hacks and mods are a good indicator of poor quality and something you do NOT want to buy for a safe system). Do due diligence and some research before sending your aircraft skyward.



Troubleshooting

- **Issue: Horizontal lines in pilot video downlink**

Solution: If there are lines in the video during flight that disappear as soon as you land, your video transmitter is exposed to too much vibrations. Memory foam in conjunction with the Flame Wheel VTx mount will take out the vibrations in an instant and give you crystal-clear video.

- **Issue: Motor(s) doesn't start**

Solution: It is probably a lazy start syndrome, some information on that is available here: bit.ly/15wNLk4. You should calibrate your ESC throttle endpoints, details on how to perform this: bit.ly/110deyX. We have a calibration cable available which speeds up the process. Please remember to remove the props before doing that.

- **Issue: Got a TBS CORE and no OSD or only voltage**

Solution: The TBS CORE needs to be enabled. This is done by soldering a bridge on the "ENABLE" pads at the face of the TBS CORE. If you only see voltage, you need to configure the CORE for the right current sensor and for current consumption display. The [manual](#) tells you all about that.

- **Issue: Want to use backup battery for TBS CORE**

Solution: A backup battery can be soldered to the two pads marked VIN2/GND but in reality it is not really advisable; if the main battery is dead the quad will fall to the ground regardless (a wing can glide to a safe landing). Additionally, since the VIN2 pads are shorted on the bottom plate, you may not connect the pin headers for VIN2 and use a backup battery system.



Recommended parts

Below is a list of compatible R/C and FPV gear for the TBS DISCOVERY quadrotor. This will hopefully make it easier to pick up spare parts and upgrades.

Power sets

 A collection of four black TBS Bulletproof 30A ESCs and four silver TBS 750kV brushless motors with M5 prop mount hubs, arranged together.	<p>TBS 750kV Motor / ESC Combo</p> <p>A very sweet Motor/ESC combination which offers great value. This is the system that was flown in most TBS DISCOVERY videos due to its long flight times (10-12mins on 4S 3.3Ah).</p> <ul style="list-style-type: none">• 4x TBS BULLETPROOF 30A ESC (flashed with SimonK Firmware)• 4x TBS 750kV Motor with M5 prop mount hubs
 A collection of four black TBS Bulletproof 30A ESCs and four black TBS 900kV brushless motors with M5 prop mount hubs, arranged together.	<p>TBS 900kV Motor / ESC Combo</p> <p>For the more sophisticated, agile-flight loving pilot or for those requiring super-vibration-resistant and high quality motors.</p> <ul style="list-style-type: none">• 4x TBS BULLETPROOF 30A ESC (flashed with SimonK Firmware)• 4x TBS 900kV Motor with M5 prop mount hubs

Individual parts

Motors

- TBS 900KV or Tiger Motors MT2216-10/11 900KV brushless motor (5mm shaft)
- TBS 750KV or RCTimer A2830-14 750KV brushless motor
- DJI 2212 920KV brushless motor (8mm shaft)
- Sunnysky 2216-12 800KV brushless motor

Speed controllers

- TBS 30A Multicopter SimonK firmware speed controller
- DJI OPTO 30A no-BEC speed controller
- Tiger Motors 18A BEC speed controller
- HobbyKing F-20A or F-30A BEC programmable ESC with SimonK firmware



Flight controller

- DJI NAZA-M with optional GPS
- OpenPilot CopterControl 3D

R/C Transmitter/Receiver

- Futaba 8FG / 7C with included receiver R6208SB / R617FS
- Graupner MX-12 radio with included GR-6 receiver
- ImmersionRC EzUHF 8ch Diversity receiver
- ImmersionRC EzUHF 8ch Lite receiver

Propellers

- Graupner E-Prop 9x5-inch propellers
- Graupner E-Prop 10x5-inch propellers
- GemFan E-Propeller 10x5 Carbon Fiber propellers
- RCTimer Carbon Fiber 9x5-inch propellers
- RCTimer Carbon Fiber 10x5-inch propellers

Battery

- TBS 4S 4500mAh 30C or KyPOM KT4500/35-4S Lipo pack
- TBS 4S 3300mAh 30C or KyPOM KT3300/35-4S Lipo pack
- Gens Ace 4S 3300mAh 25C Lipo pack
- Zippy Compact 4S 4000mAh 25C Lipo pack
- Turnigy nano-tech 4S 3300mAh 35C Lipo pack

FPV transmitter

- Lawmate TM-240500-LM 2.4GHz 500mW transmitter
- TBS ROOKIE 5.8GHz 200mW transmitter
- TBS GREENHORN 5.8GHz 25mW transmitter
- BosCam TS-353 5.8GHz 400mW transmitter
- ImmersionRC 5.8ghz 600mW A/V transmitter

FPV camera

- TBS69 or TBS59 FPV camera
- Security Camera 2000 PZ0420 or CMQ1993X (IR blocked) 600TVL camera



Spare parts

You can either get spare parts directly from us (team-blacksheep.com) or from one of our distributors and retailers near you.

Our ever-growing list of retailers is published on the left at team-blacksheep.com/shop.



Appendix

- Frame assembly diagram
- Electronics installation diagram
- Video transmitter installation diagram
- Center of Gravity diagram



Manual written and designed by *ivc.no* in cooperation with TBS.

